

5x7 CRYSTAL MINIATURE SMD

MICROPROCESSOR CRYSTAL

SPECIFICATION

Frequency Range	10 to 100 MHz
Frequency Tolerance	± 50 PPM (Standard)
Frequency Stability	± 50 PPM (Standard)
Operating Temperature Range	0EC to 70EC (Standard)
Load Capacitance (CL)	12pF to 50pF & Series
Shunt Capacitance	7pF Maximum
Drive Level	100uWatt Maximum
Aging	±3 PPM per year Maximum

Dimensions in mm

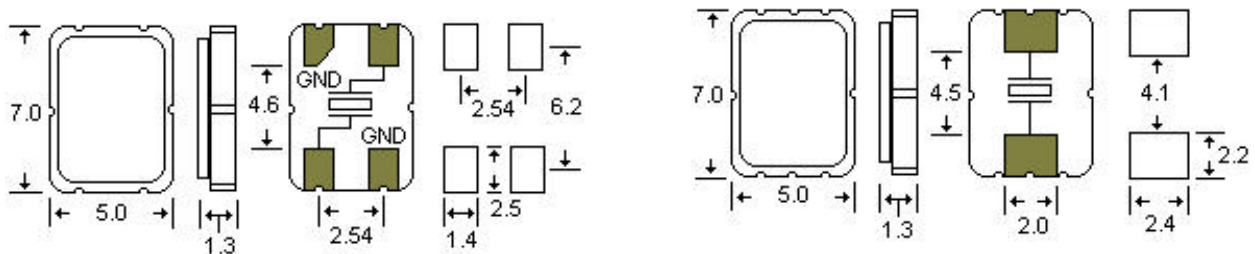

Layout

T - 2 PAD

Pad Layout

S - 4 PAD

Pad

5 x 7 MINI. SMD CRYSTAL Part Number Break Down

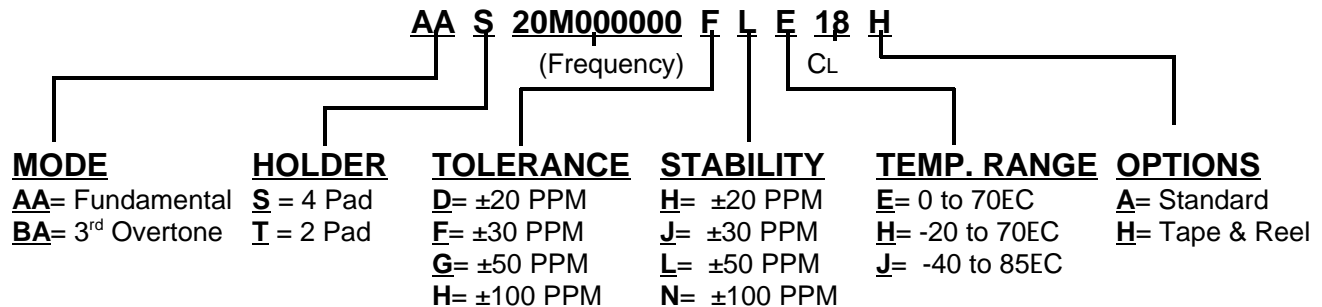

Standard Crystal Corporation 9940 E. Baldwin Place, El Monte, Ca., 91731

Phone: (800) 423-4578, Fax: (626) 443-9049

www.standardcrystalcorp.com, E-Mail: stdxtl@pacbell.net